

POLYETHYLENE Piping System

... The next generation piping



The Supreme Industries Ltd. is an acknowledged leader of India's plastic industry. It is credited with pioneering several path breaking products and has gained a valuable experience in providing innovative and cost effective piping solutions. The Company has been a trend setter and a torch bearer in the transition from conventional to advanced plastic piping products in the country. The Company's objective is to meet the growing needs of its clientele in water and waste management and in infrastructure sector through a specially designed high performance range of piping products. The innovative product portfolio offered by Supreme is extensive in nature and applications. With its range of over 7500 products, the most comprehensive in the piping industry, Supreme caters to almost every conceivable need and application in piping.

Supreme offers complete range of Polyethylene (PE) pipes up to 800mm sizes for water supply, drainage, irrigation, bore well application and infrastructure projects. Supreme PE pipes are user friendly, simple and easy to fit and equipped with many outstanding features that assures long term system performance and low maintenance cost.



The system

Supreme polyethylene pipes are a safe, long lasting and cost effective solution for potable water supply, irrigation, bore well application, drainage, sewerage and infrastructure projects. Supreme HDPE pipes are manufactured from virgin raw material with the help of state- of- the- art manufacturing facilities. The plant is equipped with R and D facilities and stringent tests are carried out on raw material and finished goods to ensure the quality as per the national and international standards. Being a pioneer in bringing innovative piping products for varied applications, continuous improvement is a regular phenomenon. All these activities are carried out with the help of experts in the field of Polymer. Supreme strongly believes in providing uncompromising quality products and services to delight the customers.

The pipes and fittings are available in complete range from 20 to 800mm sizes. The pipes are available in PN 2.5 to PN 16 pressure class in PE 63, PE 80 and PE 100 grades. Supreme PE pipes are manufactured according to IS:4984 and ISO:4427. Supreme PE pipes are tested by WRc-NSF, UK, that endorses its suitability for potable water.

Features and benefits

- High reliability and proven service performance
- Resistance to low temperature
- High impact resistance
- Abrasion resistance
- Excellent flow characteristics
- Excellent chemical and corrosion resistance
- Excellent weld-ability
- Excellent UV resistance
- Wide variety of installation methods
- Easy, quick and economical installation
- Long service life
- Excellent water hammer resistance
- Ideal in shifting soil condition and earthquake prone areas

Pipes

Size range - 20 to 800mm
Pressure class - PN 2.5 to PN 16
Grades - PE 63, PE 80, PE 100.

Fittings

All the compatible fittings will be made available in handmade form to cater system requirements.



Standards

Application	Grade	Applicable standard
Potable water mains, house connections	PE 63, PE 80 and PE 100	IS:4984, ISO:4427, DIN 8074/75, AS/NZS 4130
Rural and agricultural pipes	PE 63 and PE 80	IS:14151 (P-1)
Column pipes for submersible pumps in coil form	PE 63 and PE 80	IS:4984
Sprinkler and drip irrigation	PE 63 and above grade	IS:14151 Part - 1 and 2
Sewerage/subsoil drainage	PE 80 and 100	IS:14333
Coal handling in mines	PE 80 and 100	IS:4984, IS:14333
Industrial applications	PE 63, 80 PE 100	IS:4984, IS:14333
ID Pipes for submersible pump	PE 63, PE 80	Company standard

Dimensions and pressure rating chart for HDPE pipes (PE 80) as per IS:4984

OD	PN 2.5		PN 4		PN 6		PN 8		PN 10		PN 12.5		PN 16	
	Min	Max	Min	Max	Min	Max	Min	Max	Min	Max	Min	Max	Min	Max
20	-	-	-	-	-	-	-	-	-	-	2.3	2.8	2.8	3.3
25	-	-	-	-	-	-	-	-	2.3	2.8	2.8	3.3	3.5	4.1
32	-	-	-	-	-	-	2.4	2.9	3.0	3.5	3.6	4.2	4.5	5.2
40	-	-	-	-	2.3	2.8	3.0	3.5	3.7	4.3	4.5	5.2	5.6	6.4
50	-	-	2.3	2.8	2.9	3.4	3.8	4.4	4.6	5.3	5.6	6.4	6.9	7.8
63	-	-	2.5	3.0	3.6	4.2	4.7	5.4	5.8	6.6	7.0	7.9	8.9	9.8
75	-	-	2.9	3.4	4.3	5.0	5.6	6.4	6.9	7.8	8.4	9.5	10.4	11.7
90	2.3	2.8	3.5	4.1	5.1	5.9	6.7	7.6	8.2	9.3	10.0	11.2	12.5	14.0
110	2.7	3.2	4.3	5.0	6.3	7.2	8.2	9.0	10.0	11.2	12.3	13.8	15.2	17.0
125	3.1	3.7	4.9	5.6	7.1	8.1	9.3	10.5	11.4	12.8	13.9	15.5	17.3	19.3
140	3.5	4.1	5.4	6.2	8.0	9.0	10.4	11.7	12.8	14.3	15.6	17.4	19.4	21.6
160	4.0	4.6	6.2	7.1	9.1	10.3	11.9	13.3	14.6	16.3	17.8	19.8	22.1	24.6
180	4.4	5.1	7.0	7.9	10.2	11.5	13.4	15.0	16.4	18.3	20.0	22.2	24.9	27.6
200	4.9	5.6	7.7	8.7	11.4	12.8	14.9	16.6	18.2	20.3	22.3	24.8	27.6	30.6
225	5.5	6.3	8.7	9.8	12.8	14.3	16.7	18.6	20.5	22.8	25.0	27.7	31.1	34.5
250	6.1	7.0	9.7	10.9	14.2	15.9	18.6	20.7	22.8	25.3	27.8	30.8	34.5	38.2
280	6.9	7.8	10.8	12.1	15.9	17.7	20.8	23.1	25.5	28.3	31.2	34.6	38.7	42.5
315	7.7	8.7	12.2	13.7	17.9	19.9	23.4	26.0	28.7	31.8	35.0	38.7	43.5	48.1
355	8.7	9.8	13.7	15.3	20.1	22.4	26.3	29.2	32.3	35.8	39.5	43.7	49.0	54.1
400	9.8	11.5	15.4	18.0	22.7	26.4	29.7	34.4	36.4	42.1	44.5	51.4	55.2	63.7
450	11.0	12.9	17.4	20.3	25.5	29.6	33.4	38.7	41.0	47.4	50.0	27.7	-	-
500	12.2	14.3	19.3	22.4	28.4	32.9	37.1	42.9	45.5	52.6	55.6	64.2	-	-
560	13.7	16.0	21.6	25.1	31.7	36.7	41.5	48.0	51.0	58.9	-	-	-	-
630	15.4	18.0	24.3	28.2	35.7	41.3	46.7	54.0	57.3	66.1	-	-	-	-
710	17.4	20.3	27.4	31.8	40.2	46.5	52.6	60.7	-	-	-	-	-	-
800	19.6	22.8	30.8	35.7	45.3	52.3	-	-	-	-	-	-	-	-

Dimensions and pressure rating chart for HDPE pipes (PE 100) as per IS:4984

OD	PN 6		PN 8		PN 10		PN 12.5		PN 16	
	Min	Max	Min	Max	Min	Max	Min	Max	Min	Max
20	-	-	-	-	-	-	-	-	2.3	2.8
25	-	-	-	-	-	-	2.3	2.8	2.9	3.4
32	-	-	-	-	2.4	2.9	2.9	3.4	3.7	4.3
40	-	-	2.4	2.9	3.0	3.5	3.7	4.3	4.6	5.3
50	2.3	2.8	3.0	3.5	3.7	4.3	4.6	5.3	5.7	6.5
63	2.9	3.4	3.8	4.4	4.7	5.4	5.7	6.5	7.1	8.1
75	3.5	4.1	4.5	5.2	5.6	6.4	6.8	7.7	8.5	9.6
90	4.1	4.8	5.4	6.2	6.7	7.6	8.2	9.5	10.2	11.5
110	5.0	5.7	6.6	7.5	8.1	9.2	10.0	11.2	12.4	13.9
125	5.7	6.5	7.2	8.5	9.2	10.4	11.3	12.7	14.1	15.8
140	6.4	7.3	8.4	9.5	10.3	11.6	12.7	14.2	15.8	17.6
160	7.3	8.3	9.6	10.8	11.8	13.2	14.5	16.2	18.1	20.2
180	8.2	9.3	10.8	12.1	13.3	14.9	16.3	18.2	20.3	22.6
200	9.1	10.3	12.0	13.4	14.8	16.5	18.1	20.2	22.6	25.1
225	10.3	11.6	13.5	15.1	16.6	18.5	20.4	22.7	25.4	28.2
250	11.4	12.8	15.0	16.7	18.4	20.5	22.6	25.1	28.2	31.3
280	12.8	14.3	16.8	18.7	20.6	22.9	25.3	28.1	31.6	35.0
315	14.4	16.1	18.9	21.0	23.2	25.8	28.5	31.6	35.5	39.3
355	16.2	18.1	21.2	23.6	26.2	29.1	32.1	35.6	40.0	44.2
400	18.2	21.2	23.9	27.7	29.5	34.2	36.2	41.9	45.1	52.1
450	20.2	23.8	26.9	31.2	33.1	38.3	40.7	47.1	50.8	58.7
500	22.8	26.5	29.9	34.6	36.8	42.6	45.2	52.2	56.4	65.1
560	25.5	29.6	33.5	38.8	41.2	47.6	50.6	58.4	-	-
630	28.7	33.3	37.7	43.6	46.4	53.6	56.9	65.7	-	-
710	32.3	37.4	42.4	49.0	52.3	60.4	-	-	-	-
800	36.4	42.1	47.8	55.2	58.9	68.0	-	-	-	-

Dimensions and pressure rating chart for HDPE pipes (PE 100) as per ISO:4427

OD	PN 4 (SDR 41)		PN 6 (SDR 26)		PN 8 (SDR 21)		PN 10 (SDR 17)		PN 12.5 (SDR 13.6)		PN 16 (SDR 11)	
	Min	Max	Min	Max	Min	Max	Min	Max	Min	Max	Min	Max
20	-	-	-	-	-	-	-	-	-	-	2.0	2.3
25	-	-	-	-	-	-	-	-	2.0	2.3	2.3	2.7
32	-	-	-	-	-	-	2.0	2.3	2.4	2.8	3.0	3.4
40	-	-	-	-	2.0	2.3	2.4	2.8	3.0	3.5	3.7	4.2
50	-	-	2.0	2.3	2.4	2.8	3.0	3.4	3.7	4.2	4.6	5.2
63	-	-	2.5	2.9	3.0	3.4	3.8	4.3	4.7	5.3	5.8	6.5
75	-	-	2.9	3.3	3.6	4.1	4.5	5.1	5.6	6.3	6.8	7.6
90	-	-	3.5	4.0	4.3	4.9	5.4	6.1	6.7	7.5	8.2	9.2
110	-	-	4.2	4.8	5.3	6.0	6.6	7.4	8.1	9.1	10.0	11.1
125	-	-	4.8	5.4	6.0	6.7	7.4	8.3	9.2	10.3	11.4	12.7
140	-	-	5.4	6.1	6.7	7.5	8.3	9.3	10.3	11.5	12.7	14.1
160	-	-	6.2	7.0	7.7	8.6	9.5	10.6	11.8	13.1	14.6	16.2
180	-	-	6.9	7.7	8.6	9.6	10.7	11.9	13.3	14.3	16.4	18.2
200	-	-	7.7	8.6	9.6	10.7	11.9	13.2	14.7	16.3	18.2	20.2
225	-	-	8.6	9.6	10.8	12.0	13.4	14.9	16.6	18.4	20.5	22.7
250	-	-	9.6	10.7	11.9	13.2	14.8	16.4	18.4	20.4	22.7	25.1
280	-	-	10.7	11.9	13.4	14.9	16.6	18.4	20.6	22.8	25.4	28.1
315	7.7	8.6	12.1	13.5	15.0	16.6	18.7	20.7	23.2	25.7	28.6	31.6
355	8.7	9.7	13.6	15.1	16.9	18.7	21.1	23.4	26.1	28.9	32.2	35.6
400	9.8	10.9	15.3	17.0	19.1	21.2	23.7	26.2	29.4	32.5	36.3	40.1
450	11.0	12.2	17.2	19.1	21.5	23.8	26.7	29.5	33.1	36.6	40.9	45.1

Dimensions and pressure rating chart for HDPE pipes (PE 80) as per ISO:4427

OD	PN 5 (SDR 26)		PN 6 (SDR 21)		PN 8 (SDR 17)		PN 10 (SDR 13.6)		PN 12.5 (SDR 11)		PN 16 (SDR 9)	
	Min	Max	Min	Max	Min	Max	Min	Max	Min	Max	Min	Max
20	-	-	-	-	-	-	-	-	2.00	2.30	2.30	2.70
25	-	-	-	-	-	-	2.00	2.30	2.30	2.70	3.00	3.40
32	-	-	-	-	2.00	2.30	2.40	2.80	3.00	3.40	3.60	4.10
40	-	-	2.00	2.30	2.40	2.80	3.00	3.50	3.70	4.20	4.50	5.10
50	2.00	2.30	2.40	2.80	3.00	3.40	3.70	4.20	4.60	5.20	5.60	6.30
63	2.50	2.90	3.00	3.40	3.80	4.30	4.70	5.30	5.80	6.50	7.10	8.00
75	2.90	3.30	3.60	4.10	4.50	5.10	5.60	6.30	6.80	7.60	8.40	9.40
90	3.50	4.00	4.30	4.90	5.40	6.10	6.70	7.50	8.20	9.20	10.10	11.30
110	4.20	4.80	5.30	6.00	6.60	7.40	8.10	9.10	10.00	11.10	12.30	13.70
125	4.80	5.40	6.00	6.70	7.40	8.30	9.20	10.30	11.40	12.70	14.00	15.60
140	5.40	6.10	6.70	7.50	8.30	9.30	10.30	11.50	12.70	14.10	15.70	17.40
160	6.20	7.00	7.70	8.60	9.50	10.60	11.80	13.10	14.60	16.20	17.90	19.80

Note: Blue MDPE Pipes (PE80) for drinking water purpose are also made available in SDR 21, SDR11 and SDR 9 in 20 to160mm sizes.

Dimensions and pressure rating chart for HDPE pipes as per AS/NZS 4130

OD	SDR 41		SDR 33		SDR 26		SDR 21		SDR 17		SDR 13.6		SDR 11		SDR 9	
	Min	Max	Min	Max	Min	Max	Min	Max	Min	Max	Min	Max	Min	Max	Min	Max
20	-	-	-	-	-	-	-	-	-	-	1.6	1.9	1.9	2.2	2.3	2.7
25	-	-	-	-	-	-	-	-	1.6	1.9	1.9	2.2	2.3	2.7	2.8	3.2
32	-	-	-	-	-	-	1.6	1.9	1.9	2.2	2.4	2.8	2.9	3.4	3.6	4.1
40	-	-	-	-	-	-	1.9	2.2	2.4	2.8	3.0	3.4	3.7	4.2	4.5	5.1
50	-	-	-	-	-	-	2.4	2.8	3.0	3.4	3.7	4.2	4.6	5.2	5.6	6.3
63	-	-	-	-	2.4	2.8	3.0	3.4	3.8	4.3	4.7	5.3	5.8	6.5	7.1	8.0
75	-	-	2.3	2.7	2.9	3.3	3.6	4.1	4.5	5.1	5.5	6.2	6.8	7.6	8.4	9.4
90	-	-	2.8	3.2	3.5	4.0	4.3	4.9	5.4	6.1	6.6	7.4	8.2	9.2	10.1	11.3
110	2.7	3.1	3.4	3.9	4.3	4.9	5.3	6.0	6.6	7.4	8.1	9.1	10.0	11.1	12.3	13.7
125	3.1	3.6	3.9	4.4	4.8	5.4	6.0	6.7	7.4	8.3	9.2	10.3	11.4	12.7	14.0	15.5
140	3.5	4.0	4.3	4.9	5.4	6.1	6.7	7.5	8.3	9.3	10.3	11.5	12.7	14.1	15.7	17.4
160	4.0	4.5	4.9	5.5	6.2	7.0	7.7	8.6	9.5	10.6	11.8	13.1	14.6	16.2	17.9	19.8
180	4.4	5.0	5.5	6.2	6.9	7.7	8.6	9.6	10.7	11.9	13.3	14.8	16.4	18.2	20.1	22.3
200	4.9	5.5	6.2	7.0	7.7	8.6	9.6	10.7	11.9	13.2	14.7	16.3	18.2	20.2	22.4	24.8
225	5.5	6.2	6.9	7.7	8.6	9.6	10.8	12.0	13.4	14.9	16.6	18.4	20.5	22.7	25.1	27.8
250	6.2	7.0	7.7	8.6	9.6	10.7	11.9	13.2	14.8	16.4	18.4	20.4	22.7	25.1	27.9	30.8
280	6.9	7.7	8.6	9.6	10.7	11.9	13.4	14.9	16.6	18.4	20.6	22.8	25.4	28.1	31.3	34.6
315	7.7	8.6	9.7	10.8	12.1	13.5	15.0	16.6	18.7	20.7	23.2	25.7	28.6	31.6	35.2	38.9
355	8.7	9.7	10.9	12.1	13.6	15.1	16.9	18.7	21.1	23.4	26.1	28.9	32.2	35.6	39.6	43.7
400	9.8	10.9	12.3	13.7	15.3	17.0	19.1	21.2	23.7	26.2	29.4	32.5	36.3	40.1	44.7	49.3
450	11.0	12.2	13.8	15.3	17.2	19.1	21.5	23.8	26.7	29.5	33.1	36.6	40.9	45.1	50.2	55.4

• SDR - Standard Dimension Ratio

• Pipes are available in PE 80 and PE 100 grade with different pressure classes.

Joining techniques

Supreme Polyethylene pipes can be jointed by different means, some of the jointing techniques are as given below:

- Butt fusion • Electro fusion • Socket fusion
- Compression joint • Flanged joint • Coupling joint

Length and packaging

Size range (mm)	Coil length (m)
20 - 50	100, 200, 500, 1000
63 - 75	100, 200, 300
90 - 110	50, 100, Straight length of 6 - 12m
125 - 800	Straight length 6 - 12m

Water hammer resistance

HDPE can withstand repetitive pressure surges that exceed the static pressure rating of the pipe giving it excellent resistance to water hammer events. In DI pipe, anticipated surge pressures are the highest. Surge pressure in PE is 44% less than in PVC and 81% less than in DI. PE withstands surges up to 150-200% of design pressure.

When PE is used, piping system components are subjected to a significantly lower surge.

Butt-Welding (procedure)

Check the Wall Alignment and Gap

The alignment of the two parts should be checked at the same time. A possible misalignment on the outside must not exceed 10% of the thickness of the wall (Fig 5). If this limit is exceeded, a better clamping position is to be sought by rotating the pipe. In such a case, however, the surface must be re-planed. Important - The welding surfaces must be planed immediately prior to the joining.

Once it has attained the fusion temperature, position the heating element in the butt-welding machine. Press the parts to be joined against the heating element with the force required for equalization until the entire circumference of each of the jointing faces rests completely against it and a bead has formed. Reduce the equalization pressure almost to zero. The heating time listed in the table below is measured from this moment.

Leave parts in the butt-welding jointing machine at welding pressure until the end of the cooling period. Once the heating period has elapsed, remove the parts from heating element, which should then be removed without touching the jointing surfaces and push the parts together immediately. The change over time must not exceed the value listed in the table. Pay particular attention during jointing that the parts be moved together swiftly until the surface are about to touch. Then they should be moved together so that they are in contact along the entire circumference. Next the pressure should be increased rapidly to the present jointing within the period of time specified in the table below. This pressure must be necessary, especially shortly after the jointing pressure has been attained. (Fig 6) The jointing parts must stay in the welding machine under jointing pressure until the end of the cooling period specified in the table.

Welding bead checks

A bead should form around the entire circumference of the pipe. Jointing of two-lip point should be above the pipe circumference means always being positive. (Fig 7)

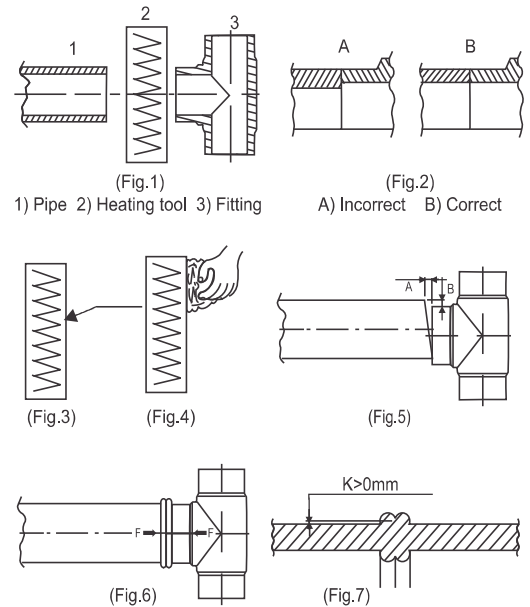

Recommended values for the heated tool butt-welding of pipes and fittings

Wall thickness (mm)	Height of bead (mm)	Heating time (sec)	Changeover time max (sec)	Time to reach full jointing (sec)	Cooling time under jointing pressure (min)
up to 4.5	0.5	45	5	5	6
4.5 -7	1.0	45-70	5-6	5-6	6-10
7 - 12	1.5	70-120	6-8	6-8	10-16
12-19	2.0	120-190	8-10	8-11	16-24
19-26	2.5	190-260	10-12	11-14	24-32
26-37	3.0	260-370	12-16	14-19	32-45
37-50	3.5	370-500	16-20	19-25	45-60
50-70	4.0	500-700	20-25	25-35	60-80

•Any specification may change without prior notice. •All information contained in this literature is given in good faith and believed to be accurate and reliable. Because of many factors which may be outside our knowledge or control and affect the use of the product, no warranty is given or implied with respect to such information, nor do we offer any warranty of immunity against patent infringement. No responsibility can be accepted for any error, omissions or incorrect assumptions.

The Supreme Industries Ltd. (Plastic Piping Division)

Corporate Office: 1161/1162, Solitair Corporate Park, Building No. 11,167, Guru Hargovindji Marg, Chakala, Andheri Ghatkopar Link Road, Andheri (East) Mumbai - 400 093. India. Tel: 91-22-67710000, 40430000

Regd. Office: 612 Raheja Chambers, Nariman Point, Mumbai 400 021. India. Tel.: (022) 22851656, 22820072
E-mail: pvc-pipes@supreme.co.in Website: www.supreme.co.in

Export Division: Tel: 91-22-6771 0126 / 4043 0126; Fax: 6771 0130

Overseas Office: Sharjah, UAE. Tel# +971 6 557 4484; Fax# +971 6 557 4485

CIN: L35920MH1942PLC003554

Branch Offices ☎ **Tel.**
Ahmedabad : 079-30028371
Bangalore : 080-30913715
Chennai : 044-39811182
Cochin : 0484-2385346
Hyderabad : 040-23221130
Indore : 0731-2432684
Jaipur : 09910995853
Jalgaon Gadegaon : 0257-3050541,42
Kanpur : 0512-2332280
Kolkata : 033-30070123
Noida (Delhi) : 0120-6660000

Authorised Distributor

