



www.armas.com.tr

SMART SOLUTIONS
FOR WATER



500 Series Plastic Hydraulic Control Valves

Agricultural Irrigation • Landscape Irrigation





● COMPANY PROFILE

ARMAŞ A.Ş. was founded in 1998 to produce valves for potable water and agricultural irrigation systems. It has become one of the leader establishments of its sector in a short time thanks to ARMAŞ makes valves.

ARMAŞ A.Ş. has given high quality services with economical prices to his costumers in industry, potable water networks and agricultural irrigation systems by means of Hydraulic Control Valves, Automatic Filtration Systems, Gate Valves, Ball Valves, Strainers, Check Valves, Air Valves and Hydrants he produced. Our company who does not sacrifice quality in production has used ISO 9001-2000 Quality Management System since 2000. In the scope of importance we gave for both human and environment, we have developed our institutional structure day by day with ISO 14001 Environmental Management System Certificate and TS 18001 Occupational Healthy and Safety Certificate since 2007.

Our products have been subjected to pressure and performance tests before sales by Quality Control Department and technical support services have been given at the installation, operation and maintenance stages after sales by our experienced engineers.

Our company who have continued R&D investments in order to present more quality and reliable products to his costumers, will continue its costumer-satisfaction focused services with increasing achievements in future thanks to his dynamic staff, powerful brand and permanent developing structure.

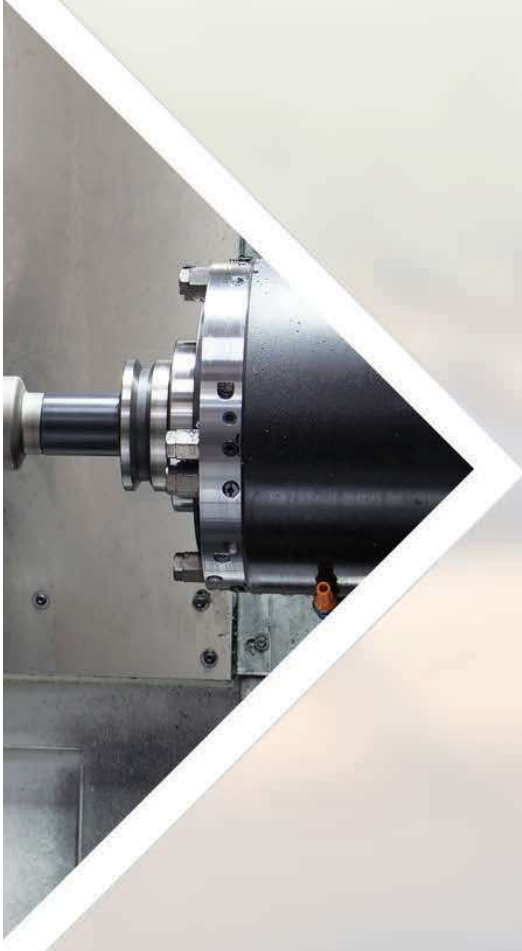

www.armas.com.tr



● TABLE OF CONTENTS



06 HYDRAULIC CONTROL VALVES

08 AVAILABLE MODELS

09 HYDRAULIC PERFORMANCE

10 MAIN PARTS

11 MANUAL CONTROL VALVE	M
11 SOLENOID CONTROLLED VALVE	EL
12 ELECTRIC CONTROL VALVE + CONTROL DEVICE (1 OUTLET)	EL/C
12 PRESSURE REDUCING VALVE	PR
13 SOLENOID CONTROLLED PRESSURE REDUCING VALVE	PREL
13 PRESSURE REDUCING AND SUSTAINING VALVE	PRPS
14 QUICK PRESSURE RELIEF VALVE	QR
14 PRESSURE SUSTAINING VALVE	PS
15 FLOAT LEVEL CONTROL VALVE	FL
15 ELECTRIC FLOAT LEVEL CONTROL VALVE	FLEL
16 FLOW RATE CONTROL VALVE	FR
16 PLASTIC AIR VALVES (KINETIC-AUTOMATIC)	PAV
17 OTHER PRODUCTS	







● GENERAL DESCRIPTION

Armaş 500 series valves are direct diaphragm closing automatic hydraulic control valves which work with line pressure. They ensure easy and smooth flow with minimum pressure losses thanks to excellent design of valve body and diaphragm. No wearable parts such as stem, bearing and seat exist in main valve body, valve life is much longer than other competitor valves. Only movable part of valve is the valve diaphragm. Armaş 500 series hydraulic control valves are designed so that it can be used in potable water force network, agricultural irrigation, filtration, industrial applications by even an unskilled personnel.

● GENERAL FEATURES

- Easy use and maintenance due to simple design
- Low cost
- Operation in wide pressure range
- Perfect modulation even in lower flow rates
- Anti-surge closing and opening with flexible diaphragm
- Full tightness thanks to reinforced diaphragm and inner spring
- Long life with Glass Reinforced Polyamide material
- Wide control application range by using different pilot valves
- Operation in both horizontal and vertical positions in application areas

● OPERATING PRINCIPLES

It is an automatic hydraulic control valve designed to make desired modulation in main valve network line as full hydraulically by means of line pressure without requiring different energy sources such as electric, pneumatic or mechanic energy.

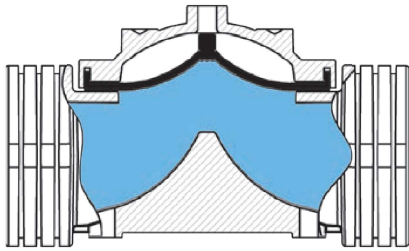

A

Valve Opening Mode

When pilot valve located on main valve being in closed position is brought into relief position, pressurized water within control chamber on main valve diaphragm is released. When line pressure (P1) reaches to a value which will overcome spring force, water carries valve to fully open position by applying a hydraulic force to valve diaphragm from bottom.

Modulation Mode

Pilot valves which are connected to main valve actuator ensure that main valve works in modulated mode. According to flow rate or pressure conditions, it ensures that main valve works in modulation mode by controlling pressure of fluid within main valve actuator (control chamber).

B

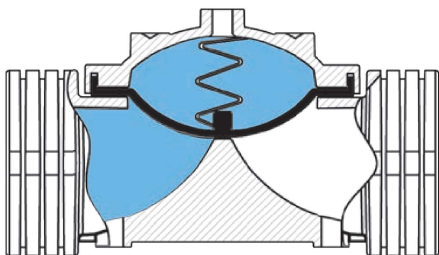
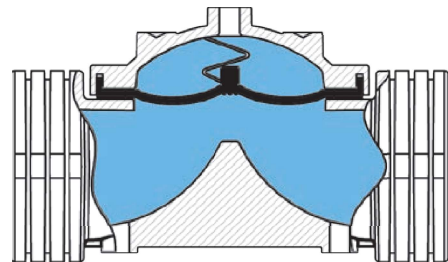

C

Valve Closing Mode



When the pilot valves on the main valve transfers the upstream water pressure to valve actuator (control chamber), water in the control chamber creates a hydraulic force on the valve diaphragm. This pressure force combined with extra force applied by inner spring, ensures that valve will be closed with full tightness.

● TECHNICAL SPECIFICATIONS

PRESSURE RANGE	Standard	0.7-10 bar (10-145 psi)
CONNECTION	Standard	Threaded (BSP or NPT)
		Flanged (ISO-ANSI)
HYDRAULIC CONNECTIONS	Standard	Reinforced Nylon Hydraulic Pipe
ACTUATOR TYPE	Standard	Diaphragm Closing Type with Single Control Chamber and Diaphragm Actuator

Maximum operating temperature:
60°C (140°F)

● AVAILABLE MODELS

MODELS	FEATURES	<div style="display: flex; justify-content: space-around;"> <div style="text-align: center;"> 55  </div> <div style="text-align: center;"> 57  </div> </div>				
	CONNECTION	Threaded		Flanged		
	MATERIAL	Glass Reinforced Polyamide		Glass Reinforced Polyamide		
	BODY TYPE	Globe		Globe		
	MAXIMUM WORKING PRESSURE	10 bar (145 psi)		10 bar (145 psi)		
	AVAILABLE SIZES		inch	mm	inch	mm
			1 ½"	Ø40	4"	Ø100
		2"	Ø50			
		2 ½"	Ø65			
		3"	Ø80			

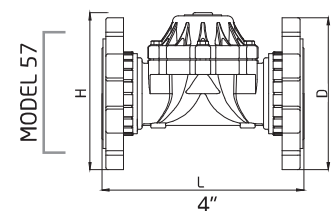
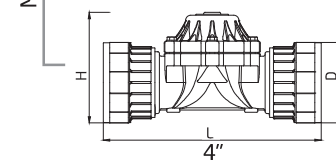
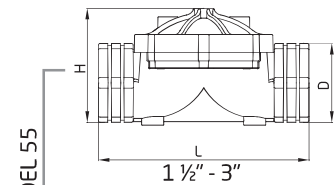

● DIMENSIONS

DN		D		L		H	
inch	mm	inch	mm	inch	mm	inch	mm
1 ½"	40	2 ½"	62	7 ⅞"	200	4 ⅜"	110
2"	50	3"	75	7 ⅞"	200	4 ⅜"	110
2 ½"	65	3 ¾"	95	9 ⅞"	250	5 ⅜"	138
3"	80	4 ¼"	109	9 ⅞"	250	5 ⅝"	145
4" (55)	100	5 ¼"	135	13 ⅞"	350	7"	180
4" (57)	100	9"	230	11"	280	9"	230

● HYDRAULIC PERFORMANCE CHART

Valve Size	mm	40	50	65	80	100
	inch	1 ½"	2"	2 ½"	3"	4"
Kv	m³/h @ 1 bar	60	70	80	90	115
Cv	gpm @ 1 psi	70	85	95	105	135
Max. Flow Continuance	m³/h	30	40	65	75	100
Max. Flow Intermittent	m³/h	45	55	95	110	145

Kv: Valve Flow Coefficient (fluid passing under 1 bar pressure difference in m³/h @ 1 bar)
 Cv: Valve Flow Coefficient (fluid passing under 1 bar pressure difference in gpm @ 1 bar)
 Q : Flow Rate (m³/h, gpm)
 ΔP: Head Loss (bar, psi)
 G: Specific weight of water (1.0 for water)

$$Kv, (Cv) = Q \cdot \sqrt{\frac{G}{\Delta P}}$$

$$Cv = 1,155 Kv$$

● HEAD LOSS CHART

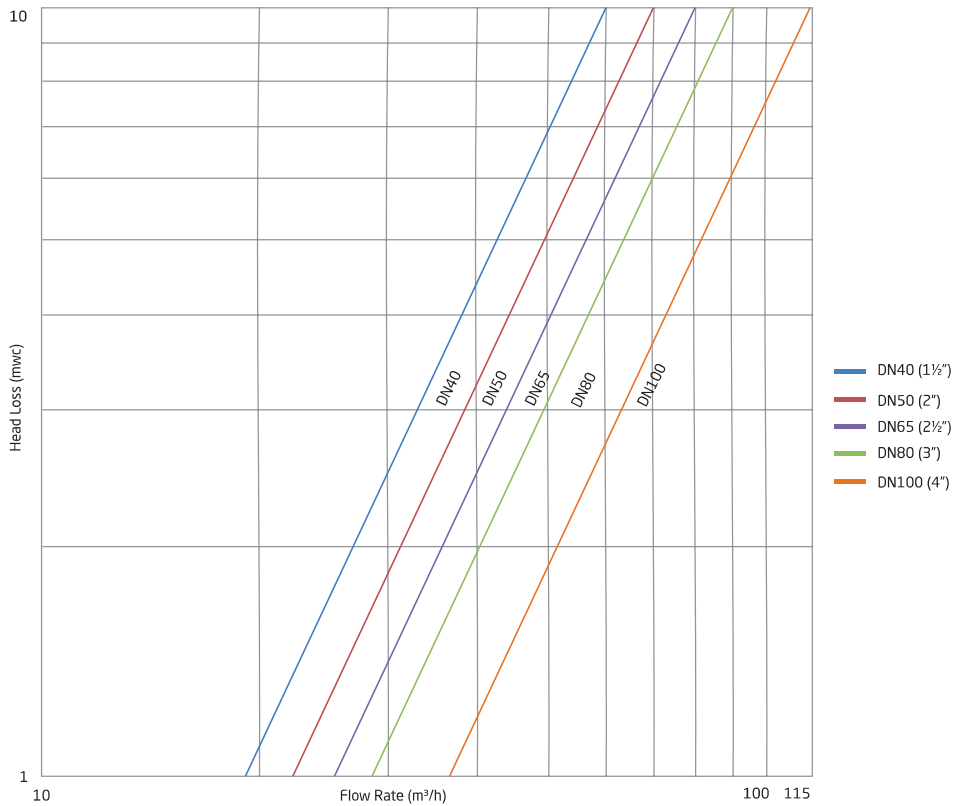

● MAIN PARTS

MAIN PARTS	NO	PART NAME	MATERIAL
	1	Body	Glass Reinforced Polyamide
	2	Bonnet	Glass Reinforced Polyamide
	3	Diaphragm	Natural Rubber
	4	Spring Thrust Ring	Glass Reinforced Polyamide
	5	Spring	SST302
	6	Bolt	SST304
	7	Nut	Brass
	8	Flange	Glass Reinforced Polyamide
	9	Flange Adapter	Glass Reinforced Polyamide
	10	Thread Adapter	Glass Reinforced Polyamide
	11	O-ring	NBR

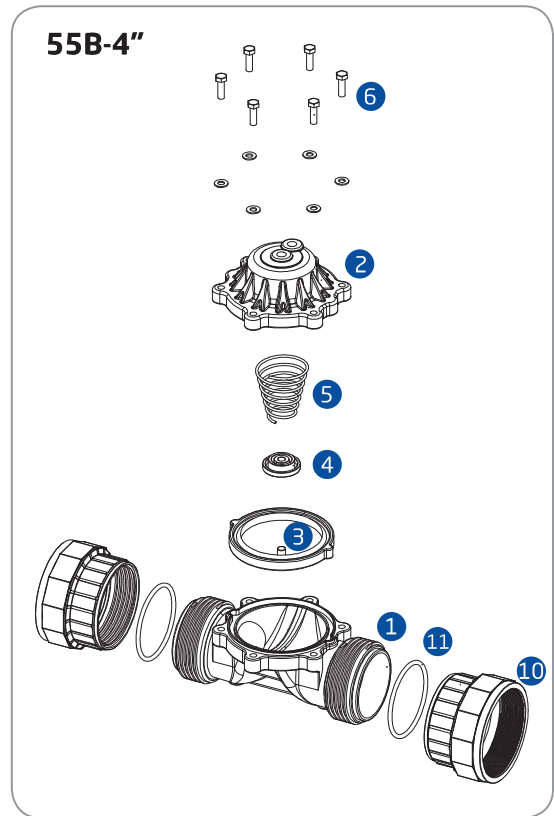
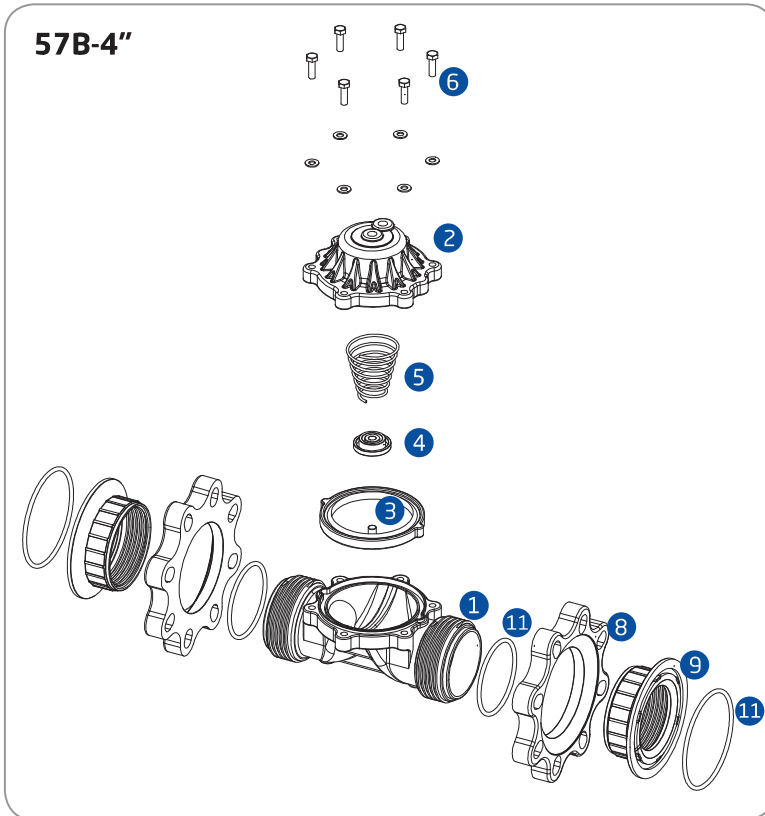
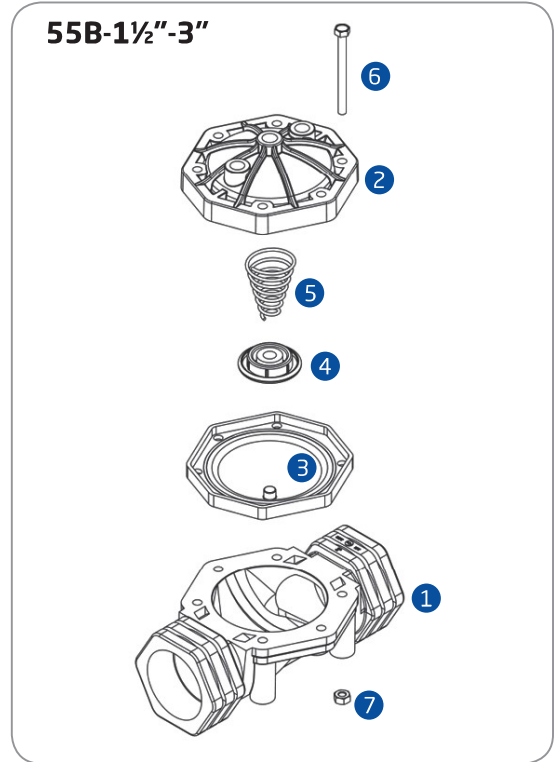

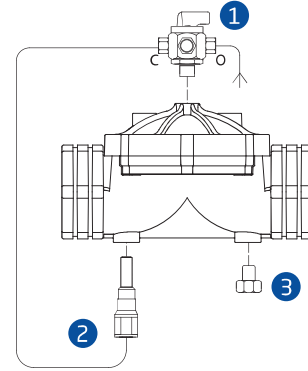

DESCRIPTION

Armas "M" model valve is the hydraulic control valve operated by line pressure and designed to ensure opening/closing process by means of a 3-way selector valve. Minimum opening pressure of valve is 0.7 bar. Thanks to its flexible diaphragm, it makes easy and fast control process in high pressure applications and is closed as fully tight without causing surge. It may be used in different applications by adding different pilot valves on its main body.

CONTROL SYSTEM COMPONENTS

- 1 3- way selector valve
- 2 In-line Finger Filter
- 3 Plug

EL SOLENOID CONTROLLED VALVE

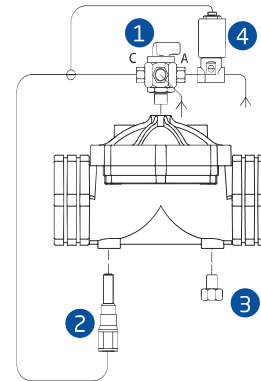

DESCRIPTION

Armas "EL" model valve is the hydraulic control valve operated by line pressure and designed to ensure opening/closing process by means of built in 3-way solenoid pilot valve controlled remotely with electric signal. Electric signal for solenoid pilot valve is ensured by means of a control device, time relay, main switch and PLC control units etc. Opening/Closing process may be realized easily thanks to manual control on solenoid pilot valve. Depending on requirements. 24V AC 50Hz/60Hz or 12V DC, 9V Latch and 12V DC Latch normally open (N.O.) or normally closed (N.C.) solenoids coils may be used on main valve.

CONTROL SYSTEM COMPONENTS

- 1 3- way selector valve
- 2 In-line Finger Filter
- 3 Plug
- 4 Solenoid Pilot Valve

ELECTRIC CONTROL VALVE + EL/C CONTROL DEVICE (1 OUTLET)

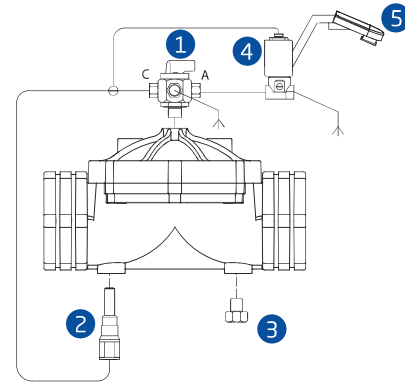

● DESCRIPTION

Armaş "EL/C" model valve is the hydraulic control valve operated by line pressure and designed to ensure opening/closing process by means of built in solenoid pilot valve controlled remotely with electric signal at required time or required duration. Electric signal for solenoid pilot valve is ensured by means of a control device, time relay, main switch and PLC control units etc. Opening/Closing process may be realized easily thanks to manual control on solenoid pilot valve. Depending on requirements. The controller irrigates in cycles, during a window of time according to your needs.

● CONTROL SYSTEM COMPONENTS

- 1 3- way selector valve
- 2 In-line Finger Filter
- 3 Plug
- 4 Solenoid Pilot Valve
- 5 Controller

PRESSURE REDUCING PR CONTROL VALVE

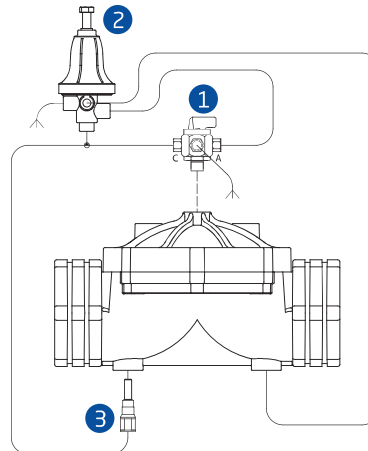

● DESCRIPTION

Armaş "PR" model pressure reducer control valve is the hydraulic control valve which reduces high upstream pressure value to desired lower pressure value by means of built-in pressure reducing pilot valves. Pressure reducer control valve controls downstream pressure value continuously and maintains it constant without being affected from flow rate and upstream pressure values. When no flow exists in the system, it closes itself automatically. When valve upstream pressure value, it is opened fully by itself. Valve may be used in vertical or horizontal positions in the system.

● CONTROL SYSTEM COMPONENTS

- 1 3- way selector valve
- 2 Plastic Pilot
- 3 In-line Finger Filter

PREL SOLENOID CONTROLLED PRESSURE REDUCING VALVE

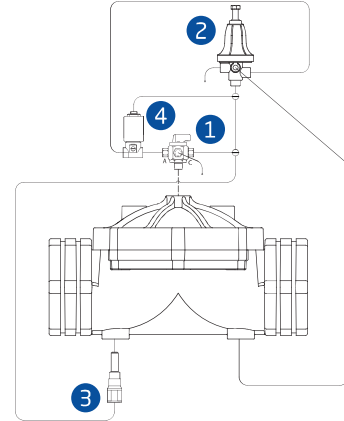

DESCRIPTION

Armaş "PREL" model pressure reducing valve is the hydraulic control valve which reduces high upstream pressure value into desired lower pressure value. Control of main valve is achieved by means of built-in solenoid pilot valves. Electric signal for solenoid pilot valves is ensured by means of a control device, time relay, main switch and PLC control units etc. Automated control may be easily ensured by this way in application systems.

CONTROL SYSTEM COMPONENTS

- 1 3- way selector valve
- 2 Plastic Pilot
- 3 In-line Finger Filter
- 4 Solenoid Pilot Valve

PRPS PRESSURE REDUCING AND SUSTAINING CONTROL VALVE

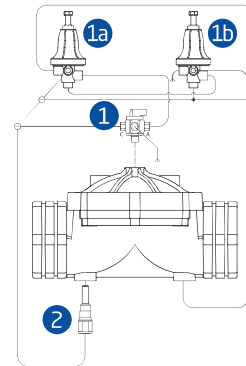

DESCRIPTION

Armaş "PRPS" model pressure reducing/sustaining hydraulic control valve reduces valve downstream pressure to desired value by sustaining upstream pressure. Two pilot valves exist on valve. Pilot valve on upstream side is the pressure sustaining pilot valve and sustains upstream pressure. Other pilot valve is pressure reducing pilot valve and keeps downstream pressure constant by reducing it to desired value. Reducing/sustaining control valve pumps fluid downwards; it ensures that system works within normal values by regulating over flow and high pressure in pumping systems. It controls upstream and downstream pressure continuously and keeps them within constant values.

CONTROL SYSTEM COMPONENTS

- 1 3- way selector valve
- 2 In-line Finger Filter
- 1a Plastic Pressure Sustaining Pilot
- 1b Plastic Pressure Reducing Pilot

QUICK PRESSURE RELIEF CONTROL VALVE QR

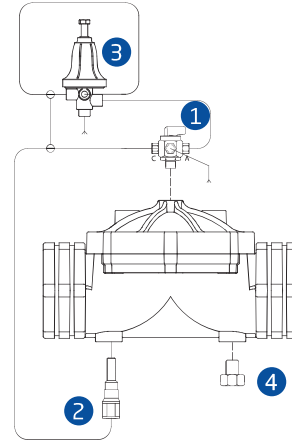

● DESCRIPTION

Armaş "QR" model quick pressure relief valve is the safety control valve designed to protect system by releasing pressure surges in water network elevation lines to atmosphere quickly, which are caused by sudden changes in water speed due to pumps put into/out of service. When network pressure exceeds set point, valve opens by itself quickly and protects system by releasing over pressure. When line pressure decreases to normal level, it is closed slowly and automatically as fully tight without causing surge.

● CONTROL SYSTEM COMPONENTS

- 1 3- way selector valve
- 2 In-line Finger Filter
- 3 Plastic Pilot
- 4 Plug

PRESSURE SUSTAINING CONTROL VALVE PS

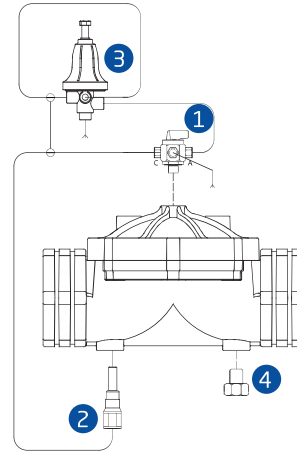

● DESCRIPTION

Armaş "PS" model pressure sustaining hydraulic control valve maintains valve upstream pressure value constant. Valve is opened when line pressure reaches the preset pressure level. It ensures that pump motor within pumping systems will start without load. It also prevents positive pressure waves caused by pump during start-up. Valve controls upstream pressure value continuously and keeps it at a constant value without being affected from changes in flow rate. When no flow exists, it closed by itself fully tight.

● CONTROL SYSTEM COMPONENTS

- 1 3- way selector valve
- 2 In-line Finger Filter
- 3 Plastic Pilot
- 4 Plug

FLOAT LEVEL CONTROL VALVE

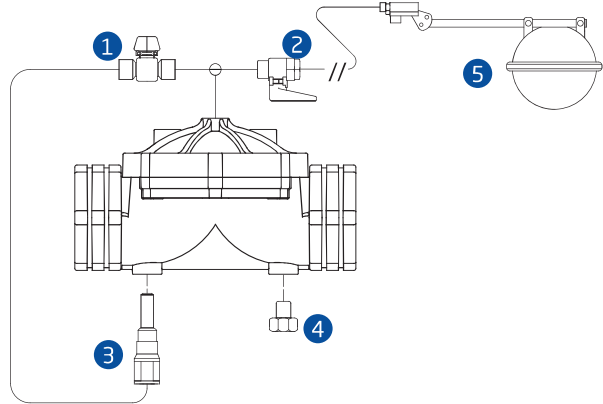

DESCRIPTION

Armaş "FL" model float level control valve is the hydraulic control valve designed to control water level in reservoirs and tanks continuously. Main valve is controlled by 2-way modulating type float pilot valve or manually. Main valve mounted on upstream of a reservoir or tank is closed as fully sealed without causing surge when water level reaches to maximum level. Valve opening/closing speed may be adjusted. It may be used in the system by mounting in horizontal or vertical orientations.

CONTROL SYSTEM COMPONENTS

- | | |
|-------------------------|---------|
| 1 Needle Valve | 4 Plug |
| 2 Ball Valve | 5 Float |
| 3 In-line Finger Filter | |

ELECTRIC FLOAT LEVEL CONTROL VALVE

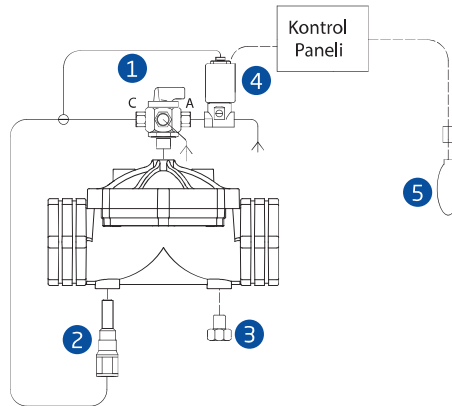

DESCRIPTION

Armaş "FLEL" model electrical float level control valve is the hydraulic control valve designed to control water level continuously by means of electrical float placed in reservoirs and tanks. Electrical float sends signal to solenoid coil on main valve when water level decreases below set level. Main valve is opened and ensures that tank or reservoir will be filled permanently. When water reaches maximum level, electrical float sends signal to solenoid coil again and main valve is closed as full sealed. Valve may be used in the system by mounting horizontal or vertical positions.

CONTROL SYSTEM COMPONENTS

- | |
|-------------------------|
| 1 3- way selector valve |
| 2 In-line Finger Filter |
| 3 Plug |
| 4 Solenoid Pilot Valve |
| 5 Electric Float Switch |

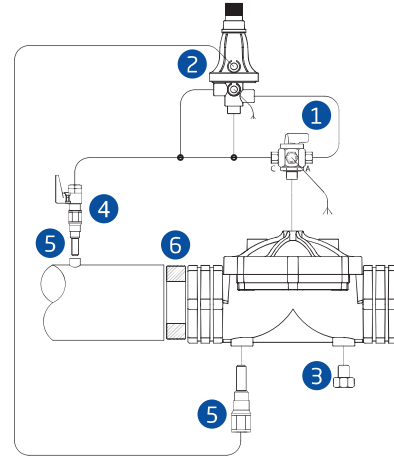

● **DESCRIPTION**

Armas "FR" model flow rate control valve is designed to limit desired flow rate. The orifice on main valve upstream creates pressure difference and 3/way differential pressure set pilot mounted in control chamber of valve senses this pressure difference and ensures that main valve opens in desired flow rate. Valve thereby limits desired flow rate automatically and keeps it fixed. It eliminates over flow by preventing excessive flow during reverse washing in filtration systems.

● **CONTROL SYSTEM COMPONENTS**

- | | |
|-------------------------|-------------------------|
| 1 3- way selector valve | 4 Ball Valve |
| 2 Plastic Pilot | 5 In-line Finger Filter |
| 3 Plug | 6 Orifice Plate |



● **DESCRIPTION**

Armas "PAV" model has been designed for an efficient discharge of large air volumes from small water network systems, filters, tanks, and other devices where trapped air may impair the system's operation. The valve is appropriate for:

- Expelling the air at high flow velocity during the initial filling of the systems
- Introducing air when the pipe drains, maintaining atmospheric pressures in the pipe, preventing collapse and cavitation damage to the conduits
- Relieving the entrained air from the water, while the network is pressurized

● **SPECIFICATIONS**

- The valve, with its unique Y-shaped duct, allows the discharge and the introduction of air. Its aerodynamic performance is superior to competitor valves of the same diameter.
 - The aerodynamic design of the float provides air flow at a very high velocity.
 - The valve design contains a very limited number of parts, allowing easy dismantling for maintenance.
 - The float does not close before the water has reached the valve.
- Automatic Air Valve: ½", ¾", 1", 2"
 Kinetic Air Valve: ¾", 1", 2"
 Connection Standards: Threaded (BSP or NPT)

● HYDRAULIC CONTROL VALVES

800 SERIES



Armaş 800 series automatic hydraulic control valves are designed in the "Y" body model type so as to show maximum resistance to cavitation under minimum head loss in high flow rates. Armaş 800 series automatic hydraulic control valves are double-chamber diaphragm actuated and disc closed type. Valve has a standard double control chamber.

Available Sizes: 2" (50 mm) - 16" (400 mm)

Available Connection Types: Flanged

Available Pressure Norms: PN16 - PN25 - PN40

600 SERIES



Armaş 600 series valves are the direct diaphragm closing automatic hydraulic control valves which work with line pressure. It ensures easy and smooth flow with minimum pressure losses thanks to excellent design of valve body and diaphragm.

Available Sizes: 1½" (40 mm) - 12" (300 mm)

Available Connection Types: Threaded, Flanged, Grooved End

Available Pressure Norms: PN10 - PN16 - PN25



BACK FLUSHING VALVES



Backflushing control valves are the 3-way control valves which are operated by line pressure or an external pneumatic pressure. Valve works in filtration and back flushing mode as coordinated with filter elements in the system.

Available Sizes: 2" (50 mm) - 4" (100 mm)

Available Connection Types: Threaded, Flanged, Grooved End

● AIR COMBINATION VALVE

AIR COMBINATION VALVES - AAV SERIES



Armaş AAV Series Automatic Air Release Valves are the valves that operate with line pressure. Armaş AAV Series Automatic Air Release Valves are the air valves that provide the venting of the air during filling and preventing of vacuum by taking air into the installation during emptying, releasing of the air that accumulates in the installation during active operation with the help of pressure and that operates in automatic manner.

Available Sizes: 2" (50 mm) - 8" (200 mm)

Available Connection Types: Flanged

● MECHANICAL VALVES



RESILIENT SEATED GATE VALVES-F4

Valve is closed or opened by moving wedge upward or downward via threaded stem mounted in the body. Wedge is rubber coated and It is not used as a check valve and flow rate adjustments.

Available Sizes: 2" (50 mm) - 24" (600 mm)

Available Connection Types: Flanged



STRAINERS

Strainer is the installation equipment which separates dirt, sediments and various foreign substances which may exist in the fluid (cold water, hot water, superheated water and steam) physically thanks to its filter and prevent them to damage other equipment in installation. Strainers are used to protect equipments such as pumps, water counters and automatic check valves from foreign matters by being mounted on intake side of this equipment.

Available Sizes: 2" (50 mm) - 16" (400 mm)

Available Connection Types: Flanged



CHECK VALVES

Swing check valve permits that water passes toward flow direction and prevents water flow in counter direction. It is manufactured in such a way that it will be closed by its own weight or by a weight mechanism. It is used in especially pumping plants to prevent back flow in case pump becomes out of service. It may be used in hot and cold water plants and with each kind of acid free gases and liquids.

Available Sizes: 2" (50 mm) - 8" (200 mm)

Available Connection Types: Flanged



ALARM CHECK VALVES

Armas FCV Alarm Check Valve is designed for wet applications where the water has no the danger of frost. The pressurized water which is inside of the pipe-line is discharged by sprinklers because of fire situation. When the discharged pressurized water system is supporting continuously, retard chamber is being full. Then, the pressure switch on the retard chamber is actuated. The pressure switch sends alarm information to fire warning system or the automation system. After the pressure switch is actuated, the water is delivered to the gong and releases a mechanical alarm.

Available Sizes: 2½" (65 mm) - 8" (200 mm)

Available Connection Types: Flanged



OS&Y GATE VALVES - NRS GATE VALVES

OS&Y Valve is a type of gate valve which is able to follow the opening/closing position by moving the stem up&down movement, is able to follow electronically the movement by adding a monitoring key, and full open position does not disrupt the flow. OS&Y Valve generates low head loss according to butterfly valves. Valve is closed or opened by moving wedge upward or downward via threaded stem mounted in the body. Wedge is rubber coated and It is not used as a check valve and flow rate adjustments.

Available Sizes: 2" (50 mm) - 8" (200 mm)

Available Connection Types: Flanged



FOR WATER

SMART SOLUTIONS

www.armas.com.tr



www.arms.com.tr

1. Organize Sanayi Bölgesi Atabey Sokak No:11/A 42300
Selçuklu / KONYA / TURKEY



T: +90 332 251 74 15 (Pbx) F: +90 332 251 74 17



export@arms.com.tr



art@marinca.net

Turkey

Discover
the potential

